

34mm Half Bridge IGBT Module

电气特性:

- 1200V 沟槽栅/场终止工艺
- 低开关损耗
- 正温度系数

典型应用:

- 逆变焊机

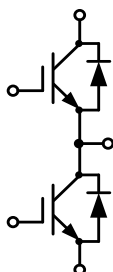
 $V_{CES}=1200V, I_{C\ nom}=100A / I_{CRM}=200A$
IGBT, 逆变器 / IGBT, Inverter

最大额定值 / Maximum Ratings

Parameter	Conditions	Symbol	Value	Unit
集电极-发射极电压 Collector-Emitter voltage	$T_{vj}=25^{\circ}C$	V_{CES}	1200	V
连续集电极直流电流 Continuous DC collector current	$T_C=100^{\circ}C, T_{vj\ max}=175^{\circ}C$	$I_{C\ nom}$	100	A
集电极重复峰值电流 Repetitive peak collector current	$t_p=1\ ms$	I_{CRM}	200	A
栅极-发射极电压 Gate emitter voltage		V_{GE}	± 20	V

特征值 / Characteristic Values

Parameter	Conditions	Symbol	Value			Unit
			Min.	Typ.	Max.	
集电极-发射极饱和电压 Collector-Emitter saturation voltage	$V_{GE}=15V, I_C=100A$ $V_{GE}=15V, I_C=100A$ $V_{GE}=15V, I_C=100A$	$T_{vj}=25^{\circ}C$ $T_{vj}=125^{\circ}C$ $T_{vj}=150^{\circ}C$	V_{CESat}	1.98 2.25 2.32	2.50	V
栅极-发射极阈值电压 Gate-Emitter threshold voltage	$I_C = 3.8mA, V_{GE} = V_{CE}$	$T_{vj}=25^{\circ}C$	$V_{GE(th)}$	4.80 5.80	6.40	
栅电荷 Gate charge	$V_{GE}=-15V...+15V$		Q_G	0.49		μC
内部栅极电阻 Internal gate resistor	$T_{vj}=25^{\circ}C$		R_{Gint}	7.83		Ω
输入电容 Input capacitance	$f=100KHz, V_{CE}=25\ V, V_{GE}=0\ V$	$T_{vj}=25^{\circ}C$	C_{ies}	6.02		nF
反向传输电容 Reverse transfer capacitance			C_{res}	0.25		

集电极-发射极截止电流 Collector-emitter cut-off current	$V_{CE}=1200V, V_{GE}=0V$	$T_{vj}=25^{\circ}C$	I_{CES}			1	mA
栅极-发射极漏电流 Gate-emitter leakage current	$V_{CE}=0V, V_{GE}=20V$	$T_{vj}=25^{\circ}C$	I_{GES}			100	nA
开通延迟时间 Turn-on delay time	$I_C=30A, V_{CE}=600V$ $V_{GE}=\pm 15V, R_G=10\Omega$ (电感负载) / (inductive load)	$T_{vj}=25^{\circ}C$ $T_{vj}=125^{\circ}C$ $T_{vj}=150^{\circ}C$	$t_{d\ on}$			152.6 167.7 176.6	ns
上升时间 Rise time	$I_C=30A, V_{CE}=600V$ $V_{GE}=\pm 15V, R_G=10\Omega$ (电感负载) / (inductive load)	$T_{vj}=25^{\circ}C$ $T_{vj}=125^{\circ}C$ $T_{vj}=150^{\circ}C$	t_r			32.3 34.2 31.2	
关断延迟时间 Turn-off delay time	$I_C=30A, V_{CE}=600V$ $V_{GE}=\pm 15V, R_G=10\Omega$ (电感负载) / (inductive load)	$T_{vj}=25^{\circ}C$ $T_{vj}=125^{\circ}C$ $T_{vj}=150^{\circ}C$	$t_{d\ off}$			312.5 409.6 441.1	
下降时间 Fall time	$I_C=30A, V_{CE}=600V$ $V_{GE}=\pm 15V, R_G=10\Omega$ (电感负载) / (inductive load)	$T_{vj}=25^{\circ}C$ $T_{vj}=125^{\circ}C$ $T_{vj}=150^{\circ}C$	t_f			66.2 93.4 130.9	
开通损耗能量 (每脉冲) Turn-on energy loss per pulse	$I_C=30A, V_{CE}=600V$ $V_{GE}=\pm 15V, R_G=10\Omega$ $di/dt=700A/\mu s (T_{vj}=150^{\circ}C)$ (电感负载) / (inductive load)	$T_{vj}=25^{\circ}C$ $T_{vj}=125^{\circ}C$ $T_{vj}=150^{\circ}C$	E_{on}			1.43 2.27 2.71	
关断损耗能量 (每脉冲) Turn-off energy loss per pulse	$I_C=30A, V_{CE}=600V$ $V_{GE}=\pm 15V, R_G=10\Omega$ $dv/dt=3000V/\mu s (T_{vj}=150^{\circ}C)$ (电感负载) / (inductive load)	$T_{vj}=25^{\circ}C$ $T_{vj}=125^{\circ}C$ $T_{vj}=150^{\circ}C$	E_{off}			1.11 1.85 2.10	mJ
短路数据 SC data	$V_{GE}\leq 15V, V_{CC}=800V$ $V_{CEmax}=V_{CES}-L_{sCE}\cdot di/dt \quad t_p\leq 10\mu s, T_{vj}=150^{\circ}C$		I_{SC}			448	A
在开关状态下温度 Temperature under switching conditions			$T_{vj\ op}$	-40		150	$^{\circ}C$

二极管，逆变器 / Diode, Inverter

最大额定值 / Maximum Ratings

Parameter	Conditions	Symbol	Value	Unit
反向重复峰值电压 Repetitive peak reverse voltage	$T_{vj}=25^{\circ}C$	V_{RRM}	1200	V
连续正向直流电流 Continuous DC forward current		I_F	30	A
正向重复峰值电流 Repetitive peak forward current	$t_p=1ms$	I_{FRM}	60	A
I^2t 值 I^2t -value	$t_p=10ms, \sin 180^{\circ}, T_{vj}=125^{\circ}C$	I^2t	490	A^2s

特征值 / Characteristic Values

Parameter	Conditions	Symbol	Value			Unit
			Min.	Typ.	Max.	
正向电压 Forward voltage	$I_F=30A, V_{GE}=0V$ $I_F=30A, V_{GE}=0V$ $I_F=30A, V_{GE}=0V$	$T_{vj}=25^{\circ}C$ $T_{vj}=125^{\circ}C$ $T_{vj}=150^{\circ}C$	V_F	1.91 1.60 1.50	2.60	V
反向恢复峰值电流 Peak reverse recovery current	$I_F=30A,$ $-di_F/dt=700A/\mu s(T_{vj}=150^{\circ}C)$ $V_R=600V, V_{GE}=-15V$	$T_{vj}=25^{\circ}C$ $T_{vj}=125^{\circ}C$ $T_{vj}=150^{\circ}C$	I_{RM}	53.8 73.9 78.7		A
恢复电荷 Recovered charge	$I_F=30A,$ $-di_F/dt=700A/\mu s(T_{vj}=150^{\circ}C)$ $V_R=600V, V_{GE}=-15V$	$T_{vj}=25^{\circ}C$ $T_{vj}=125^{\circ}C$ $T_{vj}=150^{\circ}C$	Q_r	2.09 4.65 6.19		μC
反向恢复损耗（每脉冲） Reverse recovered energy	$I_F=30A,$ $-di_F/dt=700A/\mu s(T_{vj}=150^{\circ}C)$ $V_R=600V, V_{GE}=-15V$	$T_{vj}=25^{\circ}C$ $T_{vj}=125^{\circ}C$ $T_{vj}=150^{\circ}C$	E_{rec}	0.61 1.48 2.09		mJ
在开关状态下温度 Temperature under switching conditions			$T_{vj op}$	-40	150	$^{\circ}C$

模块 / Module

Parameter	Conditions	Symbol	Value			Unit
绝缘测试电压 Isolation test voltage	RMS, f=50Hz, t=1min	V_{ISOL}	4000			V
内部绝缘 Internal isolation			Al_2O_3			
储存温度 Storage temperature		T_{stg}	-40		125	$^{\circ}C$
模块安装的扭矩 Mounting torque for modul mounting		M	3.0		5.0	Nm
端子连接扭矩 Terminal Connection Torque		M	2.5		5.0	Nm
重量 Weight		W		155		g



图 1. 典型输出特性 ($V_{GE}=15V$)

Figure 1. Typical output characteristics ($V_{GE}=15V$)

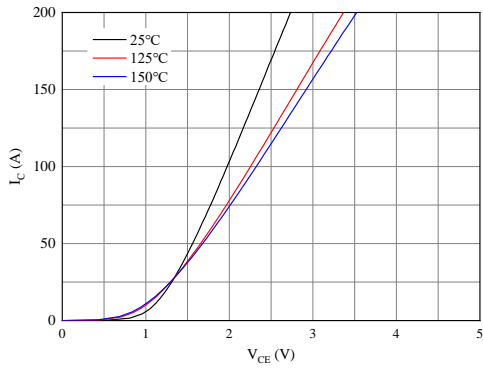

图 2. 典型输出特性 ($T_{vj}=150°C$)

Figure 2. Typical output characteristics ($T_{vj}=150°C$)

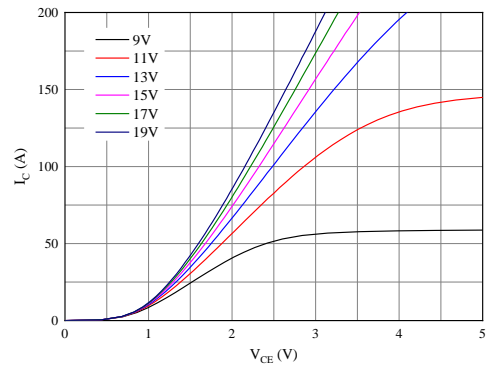

图 3. 典型传输特性 ($V_{CE}=20V$)

Figure 3. Typical transfer characteristic ($V_{CE}=20V$)

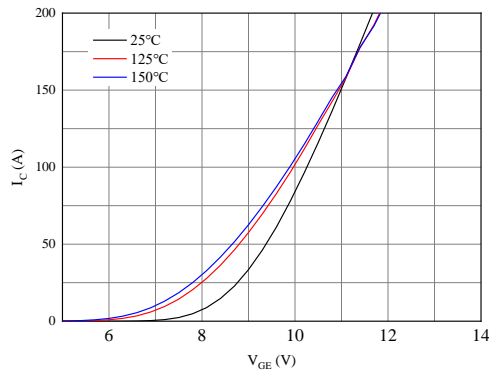

图 4. 正向偏压特性 二极管

Figure 4. Forward characteristic of Diode

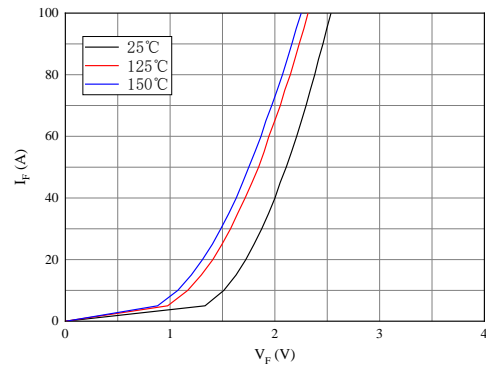

图 5. 开关损耗 逆变器

Figure 5. Switching losses of IGBT
 $V_{GE}=\pm 15V, R_{Gon}=10\Omega, R_{Goff}=10\Omega, V_{CE}=600V$

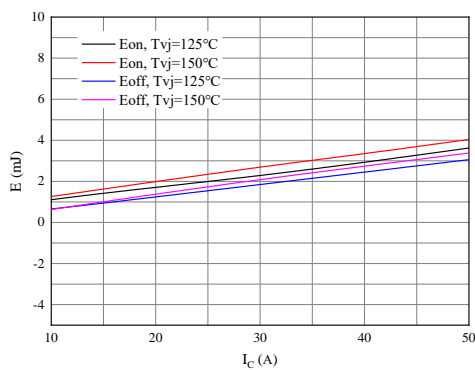

图 6. 开关损耗 逆变器

Figure 6. Switching losses of IGBT
 $V_{GE}=\pm 15V, I_C=30A, V_{CE}=600V$

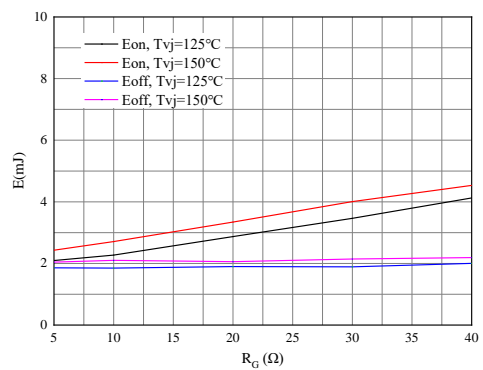

图 7. 开关损耗 二极管

Figure 7. Switching losses of Diode
 $R_{Gon}=10\ \Omega$, $V_{CE}=600V$

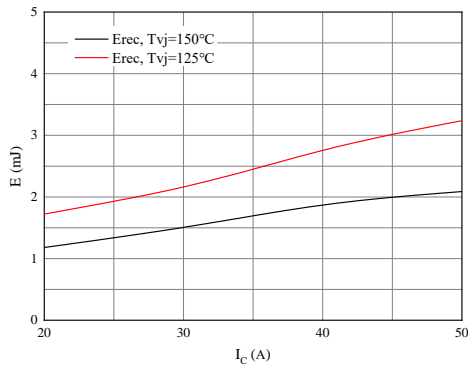

图 8. 开关损耗 二极管

Figure 8. Switching losses of Diode
 $I_F=30A$, $V_{CE}=600V$

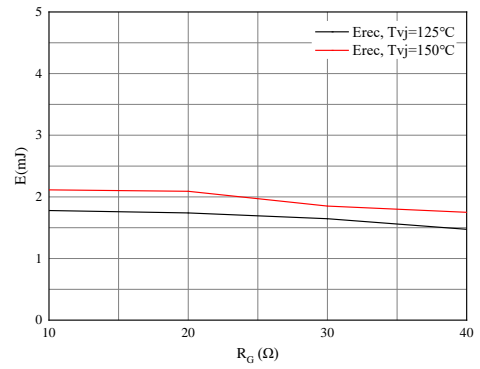

图 9. 电容特性

Figure 9. Capacitance characteristic

接线图 / Circuit diagram

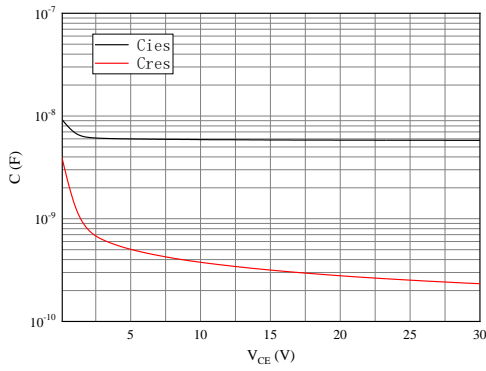
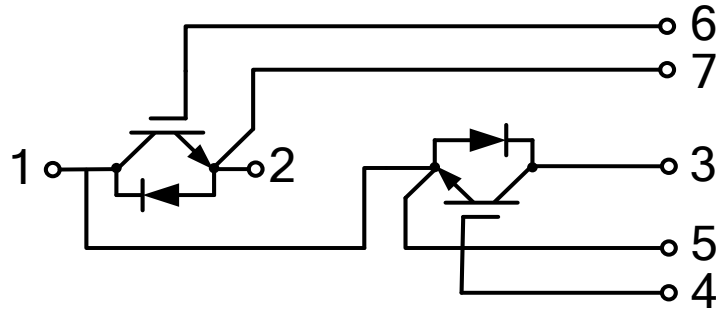

封装尺寸 / Package outlines

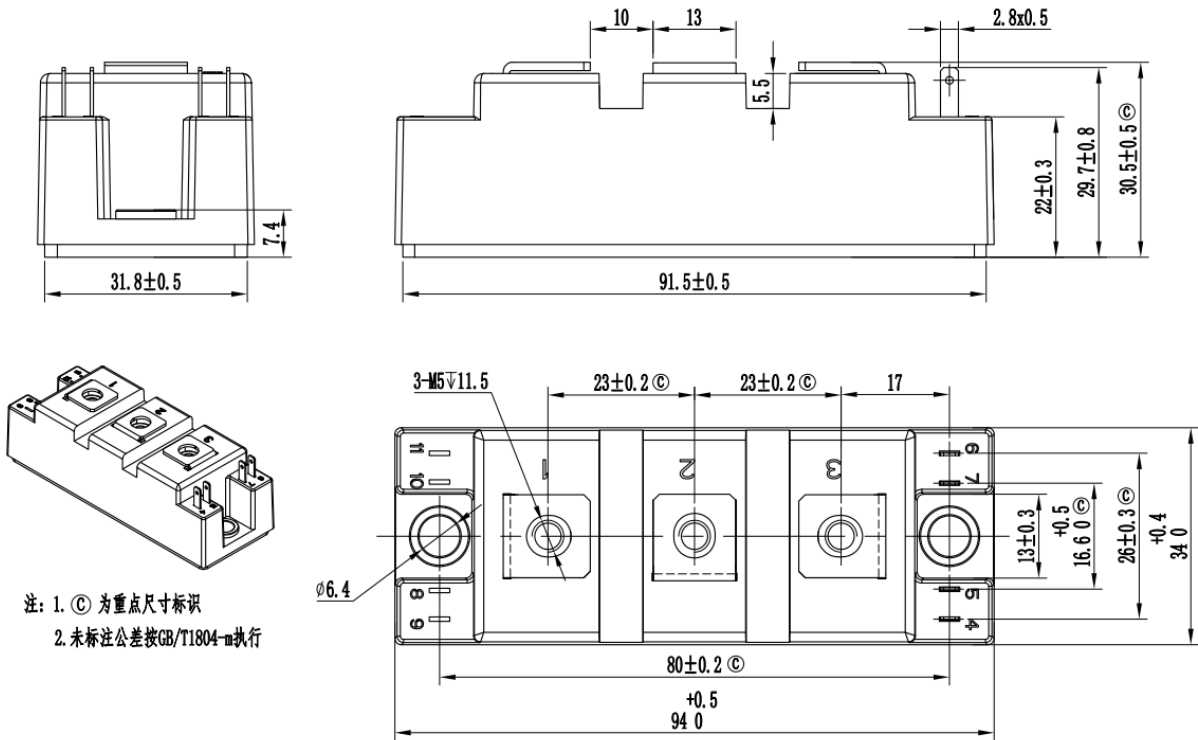

注: 1. © 为重点尺寸标识
2. 未标注公差按GB/T1804-m执行